

# User manual

(SAS51100-W)

LiFePO4 Battery

51.2V 100AH



# Contents

1. Size .....	1
2. Appearance is introduced .....	1
3. Technical Specifications .....	2
4. Comparison table of DIP switch settings .....	3
5. LED indicator description .....	4
6. Software Function Description .....	7
6.1 BLE Bluetooth function .....	7
6.2 WIFI function .....	9
7. Safety and precautions .....	10

## 1.Size

(unit: mm) (Error range:  $\pm 2\text{mm}$ )

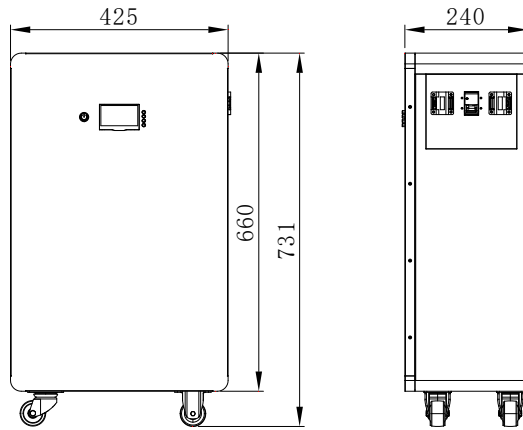

## 2.Appearance is introduced

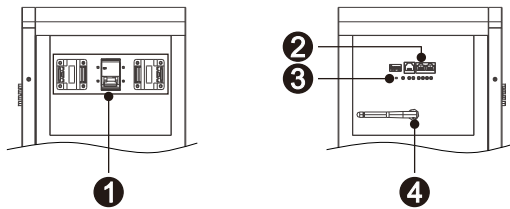

- ① Battery Interface
- ② Communication Interface
- ③ Reset Switch
- ④ Antenna

### 3. Technical Specifications

Cell type	Prismatic lithium iron phosphate
Rated capacity	5.12kWh
Nominal voltage	51.2V
Discharge voltage range	43.2-57.6V
Standard charging current	0.5C@25°C
Max. charging current	100A@25°C
Max. discharge current	100A@25°C
Depth of discharge DOD	0.9
Cycles	6000 cycles 80%DOD.@25°C
Working Temp. Range	Charge: 0°C~55°C Discharge: -20°C~55°C
Storage temperature(°C )	-15°C~50°C
Net weight (±1kg)	52.5kg (Including wheels)
Size (±2mm)	425*240*731mm (Including wheels)

**Recommendation: Charge and discharge the battery every 3 months.**

## 4. Comparison table of DIP switch settings

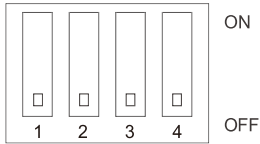

ADS	DIP Switch			
	#1	#2	#3	#4
0	OFF	OFF	OFF	OFF
1	ON	OFF	OFF	OFF
2	OFF	ON	OFF	OFF
3	ON	ON	OFF	OFF
4	OFF	OFF	ON	OFF
5	ON	OFF	ON	OFF
6	OFF	ON	ON	OFF
7	ON	ON	ON	OFF
8	OFF	OFF	OFF	ON
9	ON	OFF	OFF	ON
10	OFF	ON	OFF	ON
11	ON	ON	OFF	ON
12	OFF	OFF	ON	ON
13	ON	OFF	ON	ON
14	OFF	ON	ON	ON
15	ON	ON	ON	ON

(1) Single battery set using dial code:

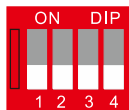

Single battery

(2) Multiple sets of batteries in parallel use the DIP settings:

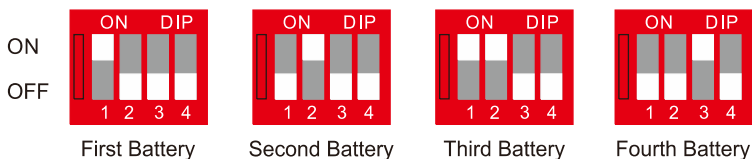

## 5.LED indicator description

Table 1 LED operating status indication









Status	Normal/Alarm/Protection	ON/OFF	RUN	ALM	Power indicator LED						Description	
												
Turn off	Dormancy	extinguish	extinguish	extinguish	extinguish	extinguish	extinguish	extinguish	extinguish	extinguish	Total extinction	
Stand-by	Normal	extinguish	Flash 1	extinguish	Based on power indicator						Standby status	
	Alerts	extinguish	Flash 1	Flash 3							Modular low voltage	
Charge	Normal	extinguish	Ever bright	extinguish	Maximum battery LED flashes (flashing 2). ALM does not flash on overcharge alarm						Maximum battery LED flashes (flashing 2), ALM does not flash on overcharge alarm	
	Alerts	extinguish	Ever bright	Flash 3								
	Overfill protection	Ever bright	Ever bright	extinguish	Ever bright	Ever bright	Ever bright	Ever bright	Ever bright	Ever bright	If there is no mains power, the indicator turns to standby	
	Temperature, overcurrent, fail-safe	Ever bright	extinguish	Ever bright	extinguish	extinguish	extinguish	extinguish	extinguish	extinguish	extinguish	Stop charging
Discharge	Normal	extinguish	Flash 3	extinguish	Based on power indicator							
	Alerts	extinguish	Flash 3	Flash 3								
	Under-voltage protection	Ever bright	extinguish	extinguish	extinguish	extinguish	extinguish	extinguish	extinguish	extinguish	extinguish	Stop discharge
	Temperature, overcurrent, short circuit, reverse connection, failure protection	Ever bright	extinguish	Ever bright	extinguish	extinguish	extinguish	extinguish	extinguish	extinguish	extinguish	Stop discharge
Failure		extinguish	extinguish	Ever bright	extinguish	extinguish	extinguish	extinguish	extinguish	extinguish	extinguish	Stop charging and discharging

Table 2 Description of capacity indication

Status	Capacity indicator	Amount of electricity						Running light
		0 ~16.6%	16.6 ~33.2%	33.2 ~49.8%	49.8 ~66.4%	66.4 ~83.0%	83.0 ~100%	
Charging	L6	extinguish	extinguish	extinguish	extinguish	extinguish	Flash 2	Ever bright
	L5	extinguish	extinguish	extinguish	extinguish	Flash 2	Ever bright	
	L4	extinguish	extinguish	extinguish	Flash 2	Ever bright	Ever bright	
	L3	extinguish	extinguish	Flash 2	Ever bright	Ever bright	Ever bright	
	L2	extinguish	Flash 2	Ever bright	Ever bright	Ever bright	Ever bright	
	L1	Flash 2	Ever bright	Ever bright	Ever bright	Ever bright	Ever bright	
Discharge	L6	extinguish	extinguish	extinguish	extinguish	extinguish	Ever bright	Flash 3
	L5	extinguish	extinguish	extinguish	extinguish	Ever bright	Ever bright	
	L4	extinguish	extinguish	extinguish	Ever bright	Ever bright	Ever bright	
	L3	extinguish	extinguish	Ever bright	Ever bright	Ever bright	Ever bright	
	L2	extinguish	Ever bright	Ever bright	Ever bright	Ever bright	Ever bright	
	L1	Ever bright	Ever bright	Ever bright	Ever bright	Ever bright	Ever bright	

## Connecting Signal Line

The parallel wiring of multiple lithium batteries is shown as follows:

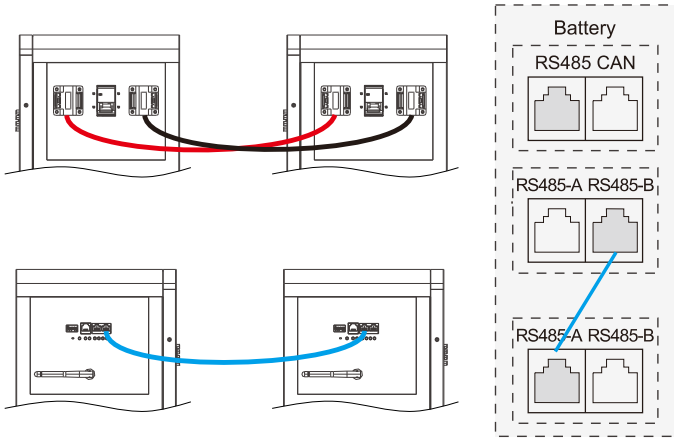

### ●Battery BMS RS485 interface definition

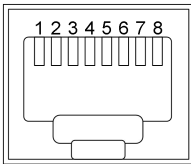

Pin number	RS485 Port
1、8	RS485-B
2、7	RS485-A
3、6	GND
4、5	NC

### ●Battery BMS CAN interface definition

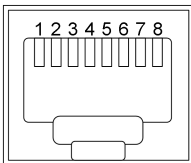

Pin number	CAN Port
9、10、11、14、16	NC
12	CANL
13	CANH
15	GND

## 6. Software Function Description

(The current software is a test version and may be updated later.)

### 6.1 BLE Bluetooth function

#### 6.1.1 Introduction to Bluetooth Function:

The communication module connects to the protection board through the UART interface. Use the mobile phone APP to connect to the corresponding Bluetooth broadcast of the communication module. After the Bluetooth connection is successful, the real-time information of the protection board can be viewed, configured, and related OTA operations can be performed.

#### 6.1.2 Bluetooth usage configuration method

Turn on the mobile phone bms\_cloud\_client app, Click "Add" at the top right corner of the homepage:



6.1.3 From the device list, find the Bluetooth broadcast corresponding to the protection board SN, click and select the Bluetooth control mode:

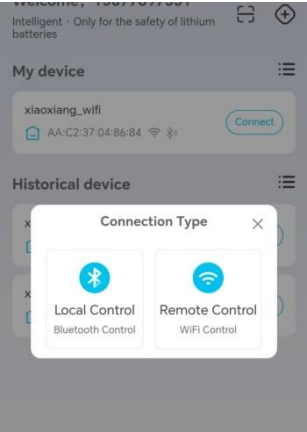

6.1.4 The connection is successful. You can view the basic parameters and Settings of the protection board in real time through the page:



## 6.2 WIFI function

### 6.2.1.WIFI Function Introduction:

The communication module is connected to the protection board through the UART interface, and the WIFI account and password information of the communication module is configured. The module is connected to the local WIFI wireless network. Through this function, the information of the protection board can be viewed, configured, monitored in real time and OTA operations can be performed on the Jiabaida web management platform and mobile APP.

### 6.2.2 WIFI usage method:

1、 Open bms\_cloud\_client app, Click "Add Device", select "WIFI Connection" as the connection method, enter the account and password for the 2.4G Hz WIFI network, and click "Connect".

Note: The communication module only supports 2.4g frequency band WIFI.

2、 When the WIFI account and password are configured correctly, log in to the Web Xiaoxiang Lithium Battery Management Platform, click on Device Management - Device List in the left sidebar, find the mac address of your device on the page, and click on the device to enter the detail page to query and configure relevant information.

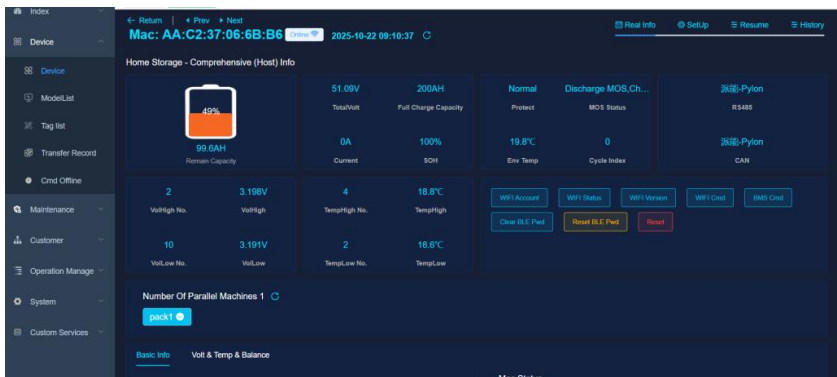

## 7.Safety and precautions

- 1) The battery module must be used in conjunction with BMS, and the mixed use of batteries from different manufacturers is strictly prohibited.
- 2) Check the battery module voltage for damage; if there is any abnormality, please stop using it.
- 3) It is strictly forbidden to stack the whole trailer battery with fork plate during transportation and storage, and it is forbidden to stack battery modules when installing and transporting batteries. There are positive and negative lead terminals or sampling line lead ends, and it is strictly forbidden to squeeze, stack and place them down.
- 4) Parallel matching requirements for battery modules: (Notes before picking and installation)
  - (1) Two identical models and same capacity, The battery modules of the same voltage are connected in parallel to 51.2V.
  - (2) Serial use is strictly prohibited.
- 5) Parallel wires are included in the battery module packing box, and the parallel wires correspond to the battery modules. Mixed insertion is strictly prohibited.
- 6) It is forbidden to use or leave the battery module near high temperature and high heat sources, away from fire and water sources.
- 7) It is forbidden to disassemble the battery module, knock, throw or step on the battery module, and dismantle the BMS and dismantle the yellow tamper-evident sticker without authorization.
- 8) Before installing the battery module, check whether the open circuit voltage of the battery is within the normal range. The "positive" and "negative" signs are printed on the module, and the electrical properties should be correctly determined. It is strictly forbidden to reverse or short-circuit the battery.
- 9) Insulation tools and gloves should be used during installation and transportation, and metal-containing conductors such as watches, bracelets (bracelets) and rings should be removed from the wrist to prevent electric shock and short-circuit the positive and negative electrodes. During installation, the battery module poles need to be insulated and protected. If the poles are close to the battery rack and other conductors, the battery poles or battery racks need to be

insulated and protected.

- 10) The recommended transportation method is for two people to carry it at the same time. The transportation tool is a safety rope or a load-bearing net bag. The battery box must be carried to the site. Violent construction is strictly prohibited to damage the product.
- 11) Please read this installation manual carefully before installation. If you have any questions, please feel free to contact us.